

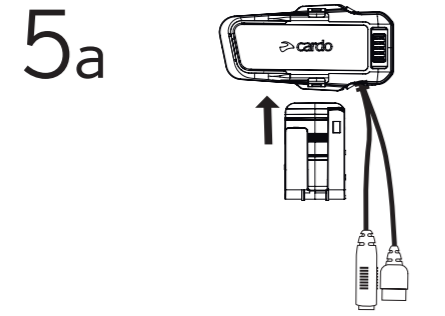

Cardo Connect App

Option 1

Installation on narrow rim helmet
 Montage an schmalem Helm
 Installation sur casque à bord étroit
 Installazione su casco con bordo stretto
 Instalación en el casco de borde estrecho
 縁が狭いヘルメットへの取り付け
 安装于窄边头盔上

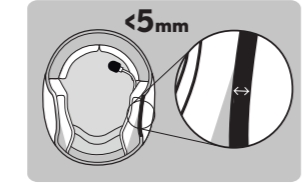

5b

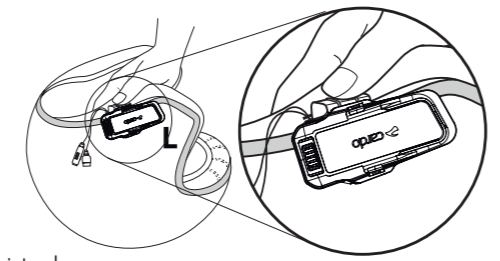

Push clamp into place
 Klemme einschieben
 Mettez l'attache en place
 Spingi l'aletta nella posizione corretta
 Empuja la abrazadera hasta que calce
 クランプを所定の位置に押し込む
 将夹钳推入就位

Option 2

Installation on wide rim helmet
 Montage an breitem Helm
 Installation sur casque à bord large
 Installazione su casco con bordo largo
 Instalación en el casco de borde ancho
 縁が広いヘルメットへの取り付け
 安装于宽边头盔上

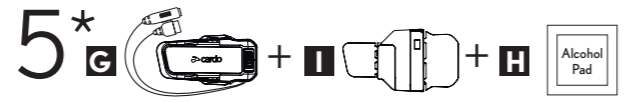
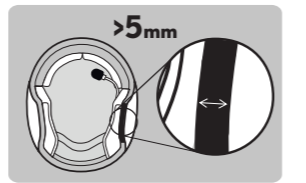

5b*

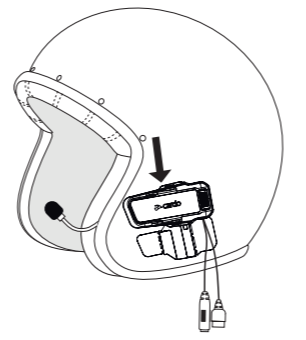
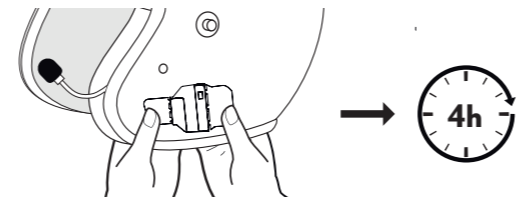
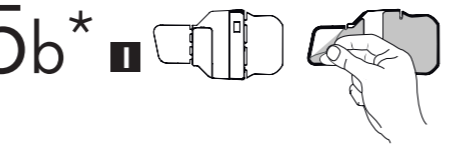

6

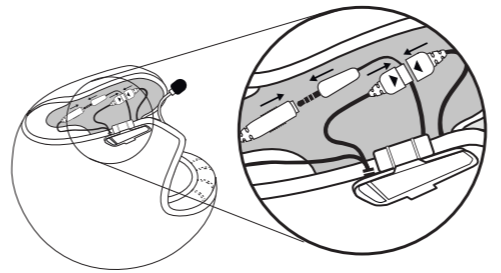

7
7a

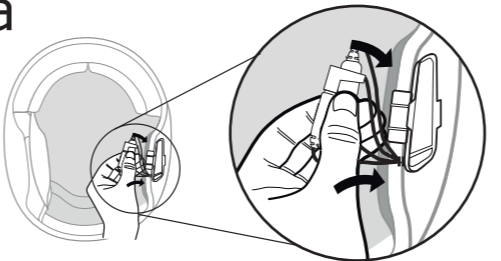

Tuck wires behind padding
 Kabel hinter der Polsterung verstauen
 Placer les fils derrière le rembourrage
 Nascondere i fili dietro l'imbottitura
 Coloque los cables detrás de los acolchados
 パッドの裏にワイヤーを隠す
 将电线塞到衬垫后面

7b

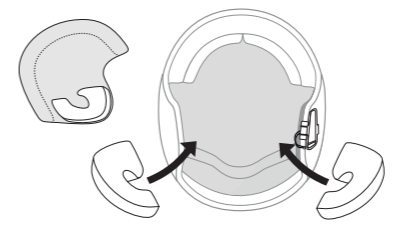

8 Optional

If needed, use booster pads to place speakers closer to ear
 Bei Bedarf Booster-Pads verwenden, um die Lautsprecher näher am Ohr zu platzieren
 Si nécessaire, utilisez des coussinets de rattrapage pour rapprocher les haut-parleurs de l'oreille
 Se necessario, utilizzare i cuscinetti per posizionare gli altoparlanti più vicino all'orecchio
 Si es necesario, use almohadillas de amplificadores para poner los altavoces cerca de la oreja
 必要に応じて、ブースターパッドを使ってスピーカーを耳に近づけます
 如果需要，请使用增强垫将耳机放置在更靠近耳朵的地方

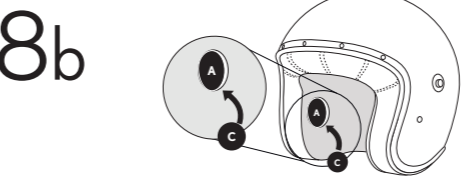
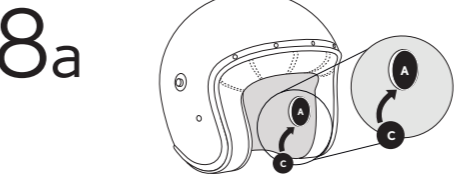

9

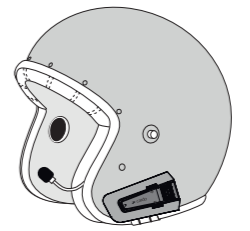

10

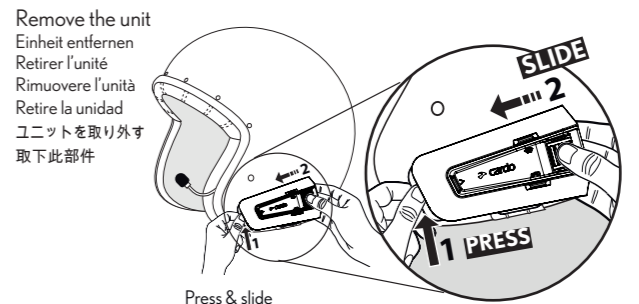

Remove the unit
 Einheit entfernen
 Retirer l'unité
 Rimuovere l'unità
 Retire la unidad
 ユニットを取り外す
 取下此部件

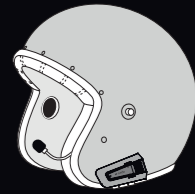
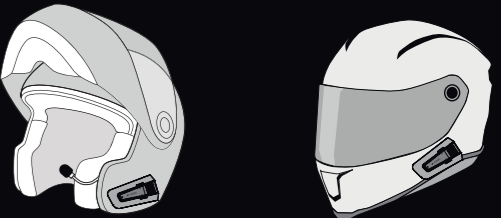

PACKTALK PRO
 Installation Guide

INSTALLATION VIDEO

Installationsvideo
Vidéo d'installation
Video d'installazione

Video de instalación
インストール動画
安装视频



CONTENTS

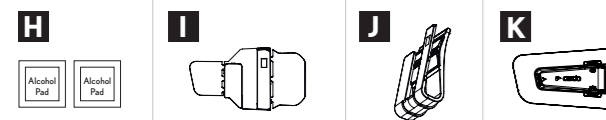
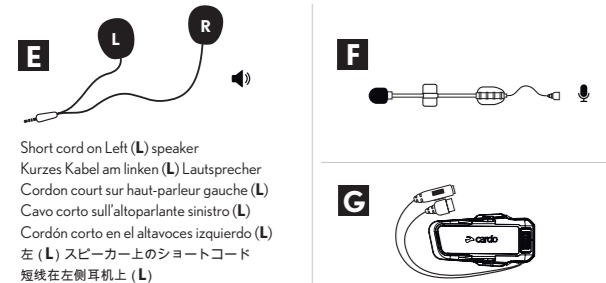
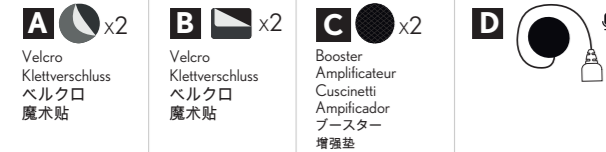

-1-

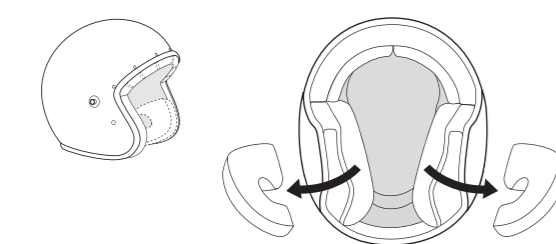
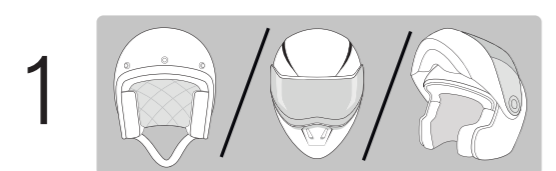

-2-

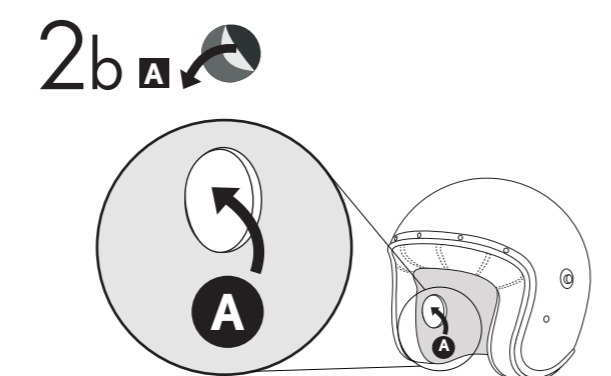
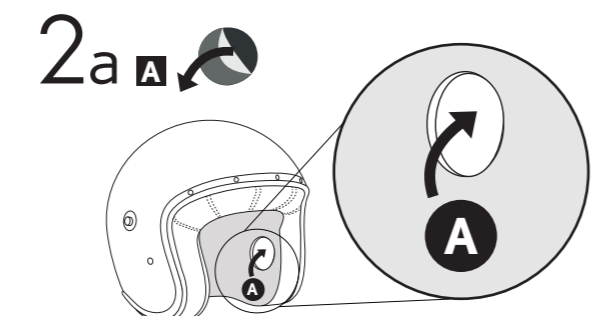

-3-

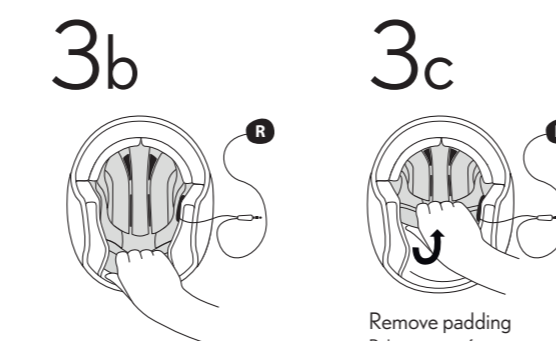
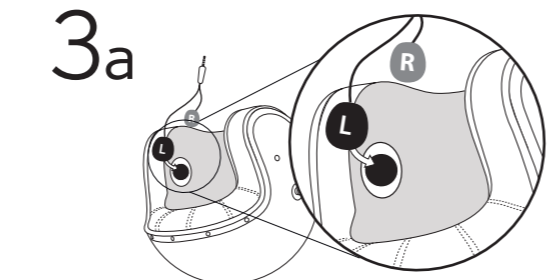
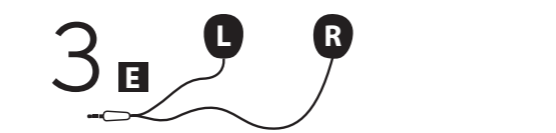

Remove padding
Polsterung entfernen
Enlever le rembourrage
Quitar el relleno acolchado
Rimuovere l'imbottitura
パディングを取り除く
移除填充物

-4-

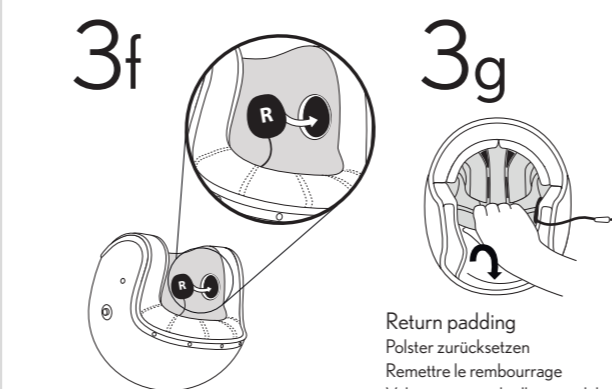

Return padding
Polster zurücksetzen
Remettre le rembourrage
Volver a poner el relleno acolchado
Reinserire l'imbottitura
パディングを付けなおす
放回填充物

-5-

Option 1

Open face helmet installation
Installation an offenem Helm
Installation sur casque jet (open face)
Installazione su casco aperto
Instalación del casco abierto
オープンフェイスヘルメットへの取り付け
敞开式头盔安装

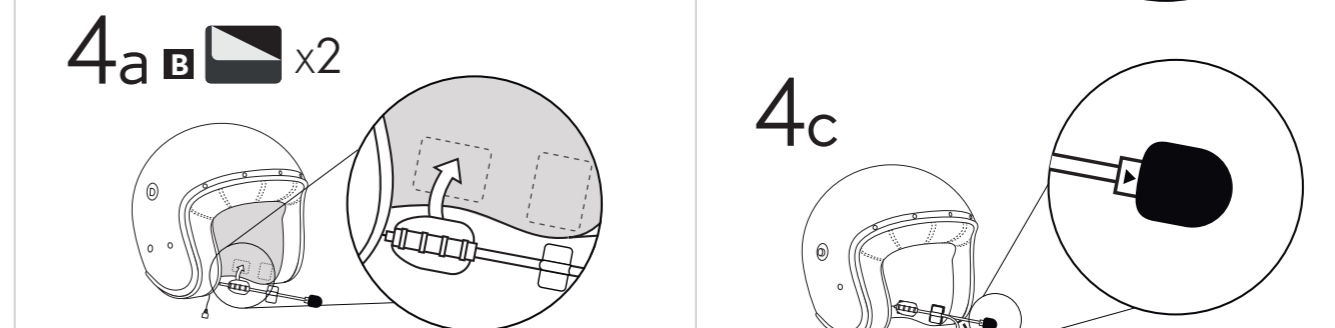

Place the mic to position the velcros
Platzieren Sie das Mikrofon, um die Klettverschlüsse zu positionieren
Placez le micro pour positionner les velcros
Posizionare il microfono per collocare i velcro
Colocar el micrófono para poner los velcros
マジックテープを位置づける為にマイクを付ける
放置麦克风以固定魔术贴

-6-

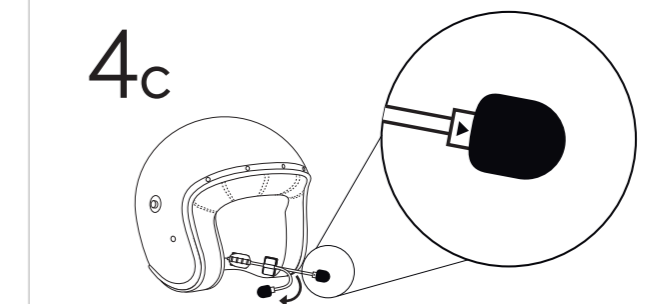
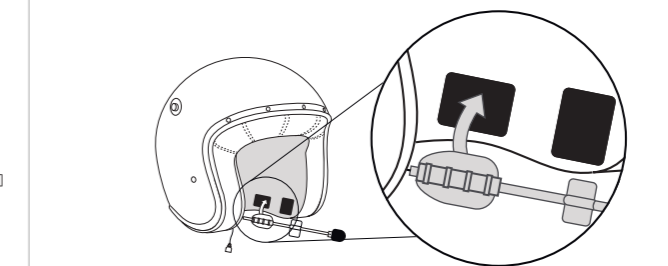
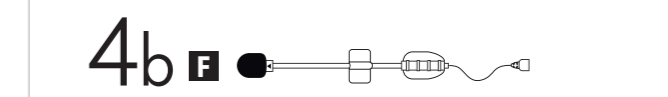

Arrow faces mouth
Pfeil zeigt zum Mund
La flèche doit faire face à la bouche
La freccia è rivolta verso la bocca
La flecha va a la boca
矢印が口に向かうように
箭头面向嘴部

-7-

Option 2

Full face helmet installation
Installation an Integralhelm
Installation sur casque intégral
Installazione su casco integrale
Instalación en el casco de cara completa
フルフェイスヘルメットへの取り付け
全面罩式头盔安装

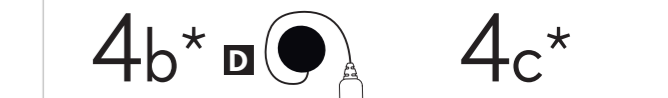

-8-